

Standard Full Nut

Thread Type: Metric - Coarse

Thread Direction: Right Hand

Material: Carbon Steel

Class Grade: Low Tensile Class 4.6

Finish: Black Zinc

Corrosion Protection Level: Moderate

Standard: AS 1112

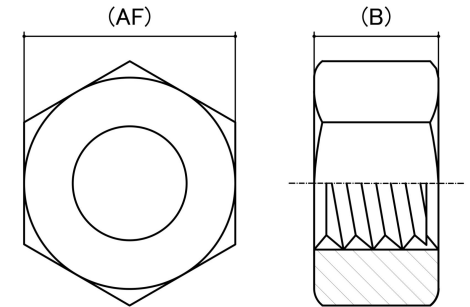

*CAD drawings shown for graphic representation only.**

Size	Thread Pitch (mm)	Thread Type	Overall Nut Height (B) (mm)		Across Flats (AF) (mm)		Spanner Size (AF) (mm)	sku (qfind)
			Min	Max	Min	Max		
M3	0.50	Coarse	2.15	2.40	5.32	5.50	5.5	413BZ
M4	0.70	Coarse	2.90	3.30	6.78	7.00	7	414BZ
M5	0.80	Coarse	4.40	4.70	7.78	8.00	8	415BZ
M6	1.00	Coarse	4.90	5.20	9.78	10.00	10	416BZ
M8	1.25	Coarse	6.44	6.93	12.73	13.00	13	418BZ

Disclaimer:

Dimensional data and technical information was obtained from publically available sources and not acquired through standard agencies. It has been completed and compiled for reference purposes only; where discrepancies are found they are subject to change without notice. Bolt & Nut Australia makes no warranties or representations regarding the accuracy and validity of the compiled information and data. Contact the relevant standard authorities for accurate and detailed information.

* CAD drawings may not reflect diameter, thread length or overall length.

© Bolt & Nut Australia Pty Ltd. All rights reserved.

Version: 18 Mar 2024